

E-Drive 



***Electronic
OneTouch system
for Prime drawers***



**FORMENTI &
GIOVENZANA**



Simple and effective

To respond to the need of minimalistic handle free kitchen and bathroom design, FGV are offering **E-Drive**, the electro-mechanic OneTouch system to operate Prime drawers. The touch of the hand, the swing of the hip or the pressure of the knee open the drawer in comfort and ease to allow access. Or a single push on a touch-panel operates the device effortlessly. The drawer can be closed as usual with the SlowMotion damping system ensuring silence and safety. Ease of assembly, Backup battery and Nanny® children safety are integral parts of the universal kit.

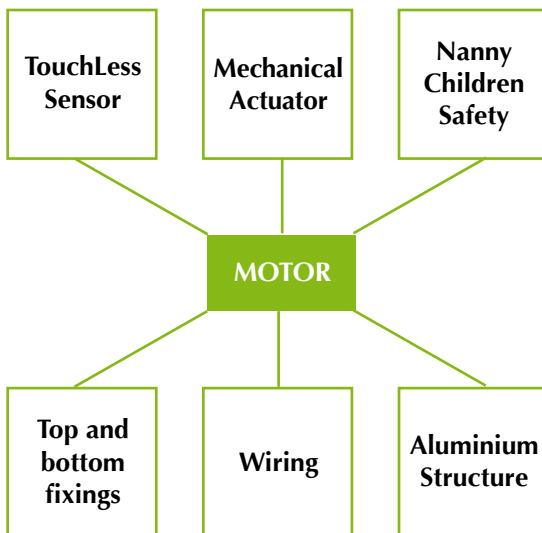

E-Drive is a simple and affordable modular OneTouch system with integrated safety features. With few components and easy to install and to use, **E-Drive** is the electro-drive for drawers.

The system is composed by:

- A back frame which can host up to 5 motors
- Electro-drive motors which power each individual drawer separately
- Activation peg on the back of the drawer or touch panel to trigger the opening
- Electronic module to command the system and hosting the backup battery for failure mode
- Optional Nanny® children safety device which can be assigned to individual drawers and deactivated at will
- Mains cable and simple and fool-proof wiring system

For comfort and ease of access of drawer content everywhere in no time!

Safety and ease of use

The heart of the system is the electro-drive which has been designed for low consumption and long lasting highest safety. Every motor module can be triggered via gap spacer and motion sensor. For gap less kitchen design, the touch panel to be put discretely on the worktop or another adequate zone gives full comfort without contortions. On the easily accessible front part of the motor sits also the switch to activate or neutralise the optional Nanny® children safety device as indispensable complement for families with small children.

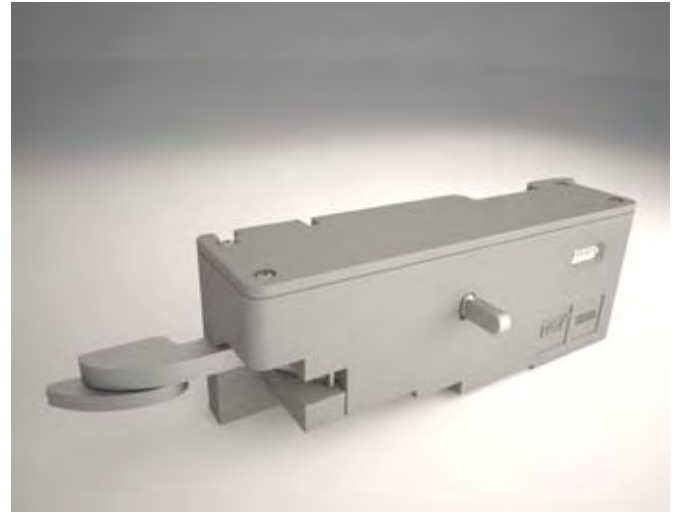

E-Drive

The right solution

E-Drive and SlowMotion as ideal complements

E-Drive is developed as the ideal complement of Prime and Prime Ten drawer systems with SlowMotion dampening system to reduce noise during the closing. The comfortably pushed open drawer can be closed as usually and its movement will be dampened during the final phase of closure to avoid noise and increase safety.

Many advantages:

- Use on standard Prime and Prime Ten drawers and easy to retrofit into existing installations
- Back frame with minimal protrusion behind the drawer (43.5mm) and easy to cut to dimension and to fix
- Plug-on electro-drives with unique cam design for fast and long push-out and with integrated anti-pinch mode in case of obstacle in front of the drawer during the push-open process
- Simple fool proof wiring system between the electronic central and the motors. Driven with safe 24 volts and simple plug and play operating system.
- Dual triggering system via gap activator and sensor or via touch panel for more comfort.
- Backup-battery integrated in electronic module and optional freely activable Nanny® children safety device

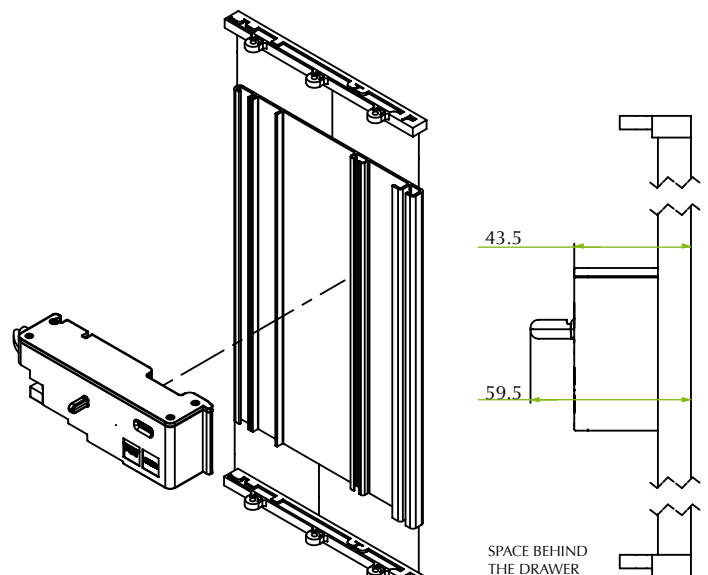

www.fgv.it

Via Concordia, 16
20050 Veduggio con Colzano (MI) - ITALY
Tel. +39 0362 947.1
Fax +39 0362 998788

